



SUPQR SCORPION

Assembly Manual

AVIATION DESIGN

ZI le chenet, 91490 Milly La Foret, FRANCE

Tel : 33 1 64 98 93 93

Fax : 33 1 64 98 93 88

E-mail : aviation.design@wanadoo.fr

www.adjets.com

Version 01/03/2007

INTRODUCTION

SCORPION is our new jet trainer. It is fully composite, delivered assembled and painted.

It is designed for jet beginner with following objective :

- Very easy to fly.
- Short take off and landing due to big airfoil thickness (13%), large flaps and low wing loading
- Very fast assembly
- Easy access to engine (big engine hatch)
- Easy access to fuel tank , ECU and radio with a large fuselage hatch
- Easy radio installation with big fuselage hatch and servo cover supplied

The **SCORPION** is fully molded in composite material.

The model comes to you finished, fully molded in composite material and painted in mold. All bulkeads are glued. All control surfaces are hinged. No gluing are required. This model has plug in wings, stabs and fin booms for an easier transport.

All necessary hardware are included in the parcel

Assembly require only few hours to fit engine and radio.

SCORPION ARF model includes :

- High quality epoxy-glass fuselage painted.
- All plywood and wood parts premounted.
- Fully molded wings with winglets, stabs and fins painted
- High tensile aluminum wing joining tube.
- Access hatch and canopy requiring no additional framework.
- All hardware (screws, servo cover, ...)
- Instructions in English with pics.

Parts required to complete the kit :

- Clear canopy
- Cockpit detail kit
- 4 liters kevlar fuel cell
- or 4 liters tank + UBT
- Deluxe retractable landing gear with special CNC oleo legs and wheels set on bearing + brakes
- Or Deluxe gear + 2 electrovalves for gear and brakes
- Air brake or air brake with electrovalve
- Stainless steel tailpipe



DISCLAIMER

AVIATION DESIGN assumes no liability for the operation and use of these products. The owner and operator of these products should have the necessary experience and exercise common sense. Said owner and operator must have a valid Model Airplane licence and insurance as required.

Assembly Instructions

Installation of the radio equipment

Components need:

Elevator: 4 servos 8 kg torque

Rudder: 2 servos 6 kg torque

Ailerons: 2 servos 8 kg torque

Flaps: 2 servos 8 kg torque

Steering nose wheels: 1 servo 5 kg torque

Receiver and switch

We also recommend the use of a Power box system or similar system required for the big number of high torque servos

Joining front fuselage to rear fuselage

Insert 6 x 3 mm blind nut in the rear section

Screw the front fuselage to the rear fuselage with six 3 mm x 20 mm allen screws

To disassemble the front fuselage you will have to remove the fuel tank

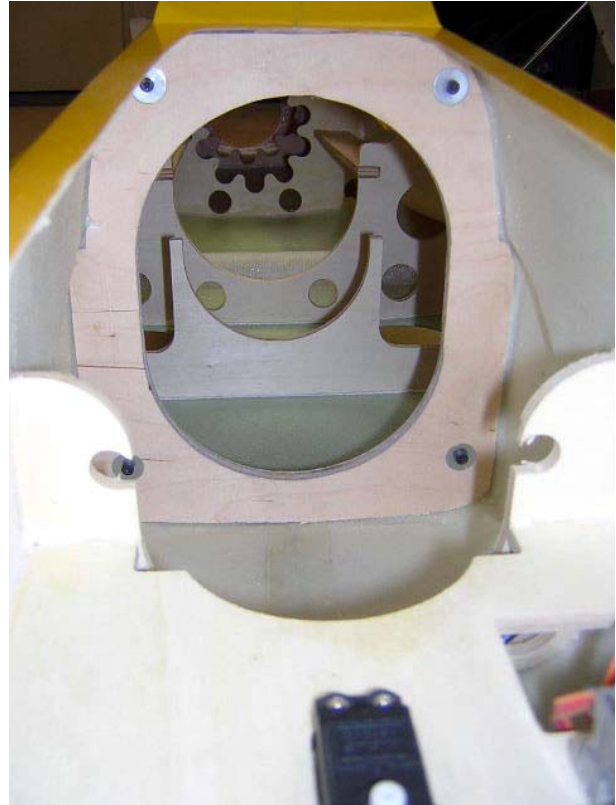

Gear :

Please, use only the oleo legs supply by Aviation Design.

If you use standard oleo, you will have to modify the gear position and gear door position

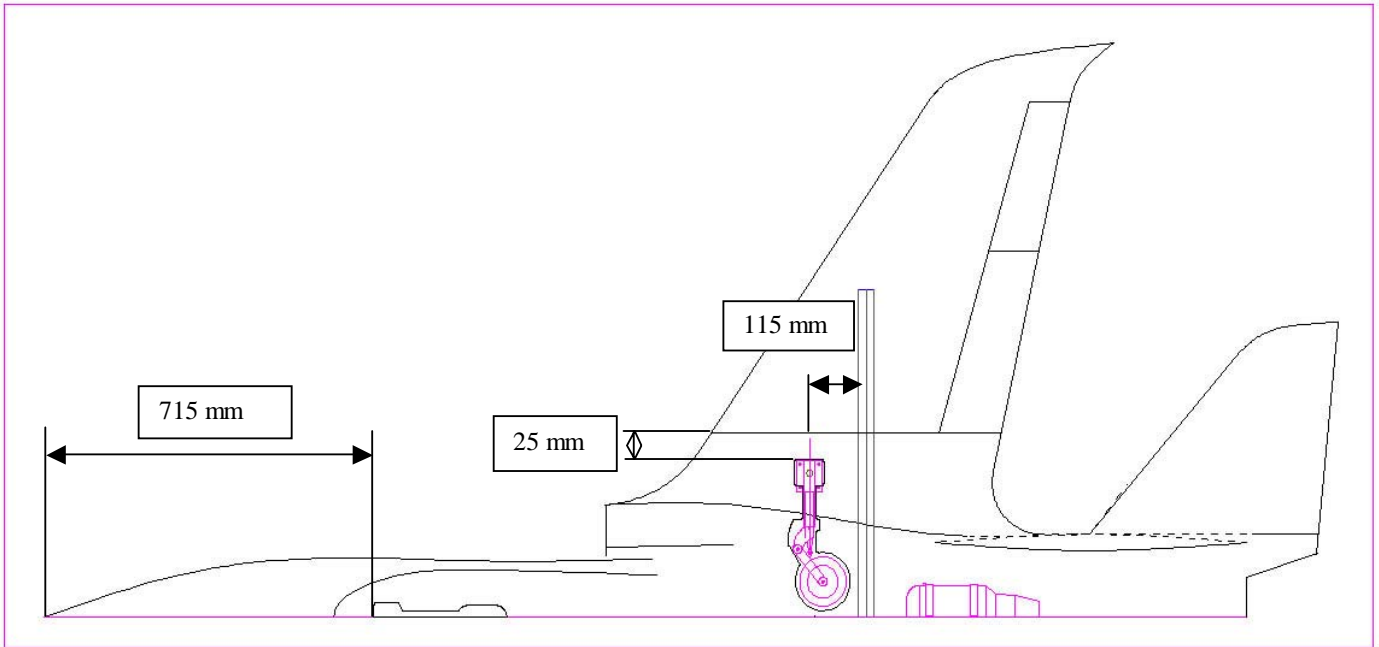

Draw the fuselage axis under the fuselage with a ruler

Draw the front gear door location and main gear door location according to the drawing and template

Cut all gear doors using a fine diamond disc and dremel tool



Fit the main gear on the plywood mount a drill four 6 mm hole in the fuselage in front of the screw location

Screw each gear with four 3x20 mm parker screws

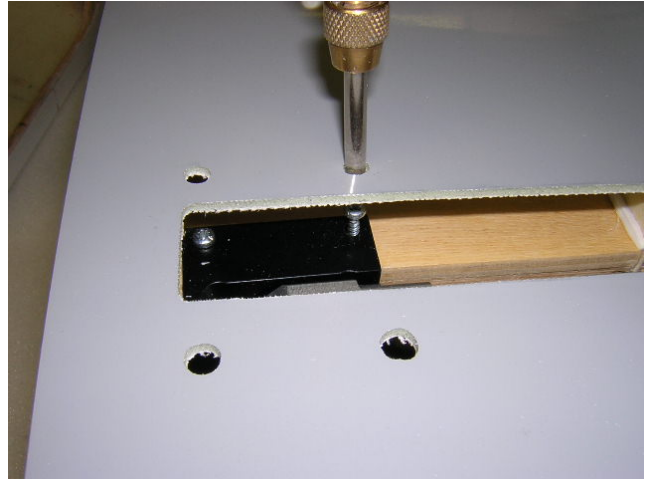
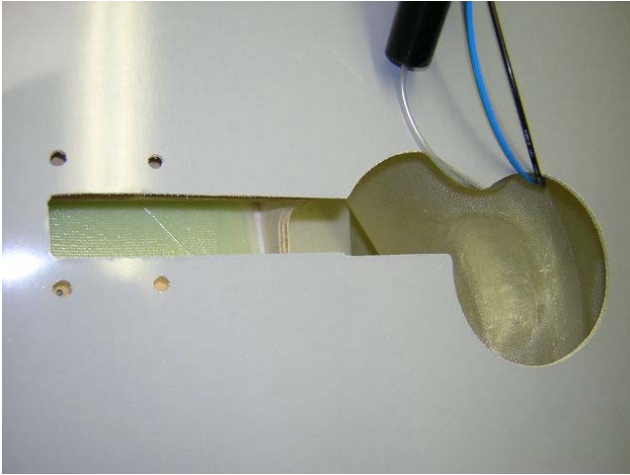

Fit the front gear on the plywood mount

Drill 4 x 2 mm hole

Screw the front gear with four 3x20 mm parker screws

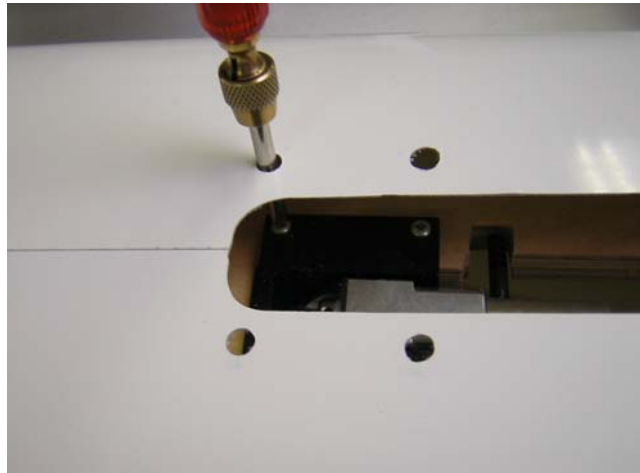

Screw the steering servo inverted on the plywood frame

Make a hole in the plywood frame for the steering steel wire.

Connect servo to steering arm with 2 mm link + steel wire .

Check that the nose gear retract and extend without problem with the steering wire.



Connect all gear tubing as described in the gear manual
Fit the brake tubings and attach them with T rap

The air bottle can be fitted under the plywood plate in the nose. You can hold it with T rap

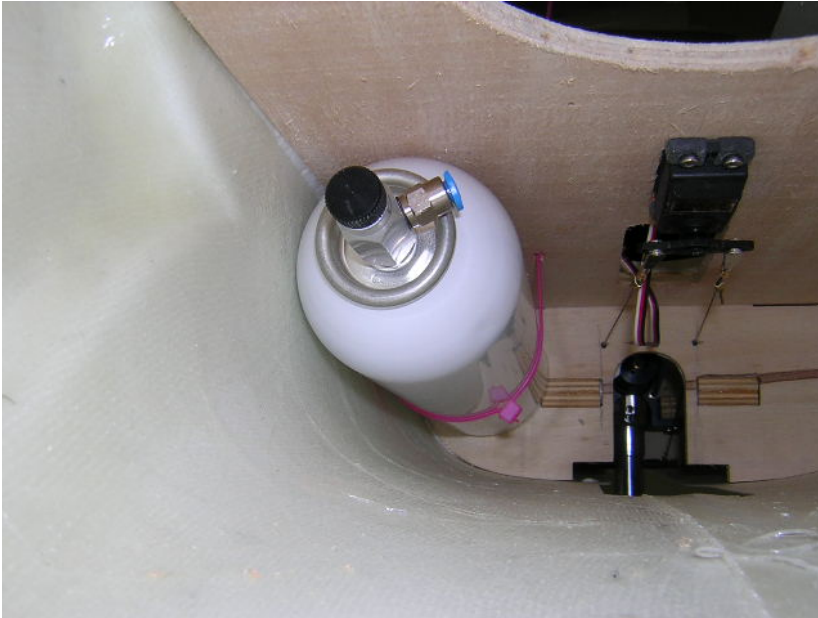

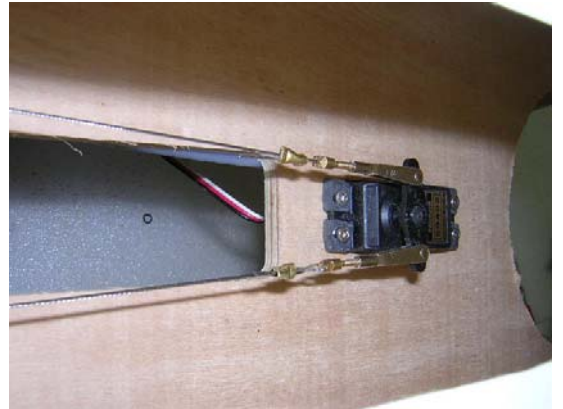

If necessary, add 2 soft springs or rubber bands to extend the wire when the front gear retract

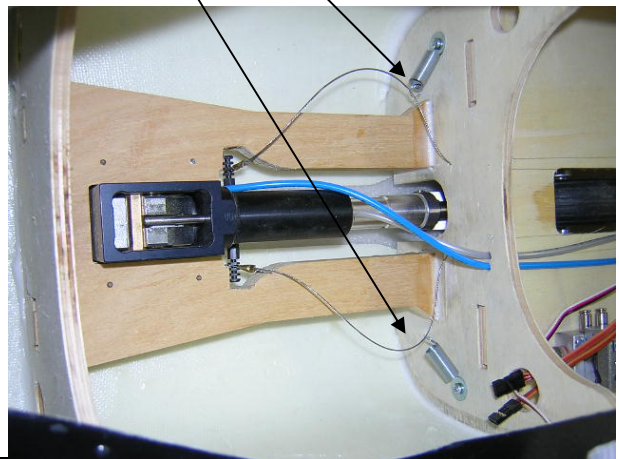
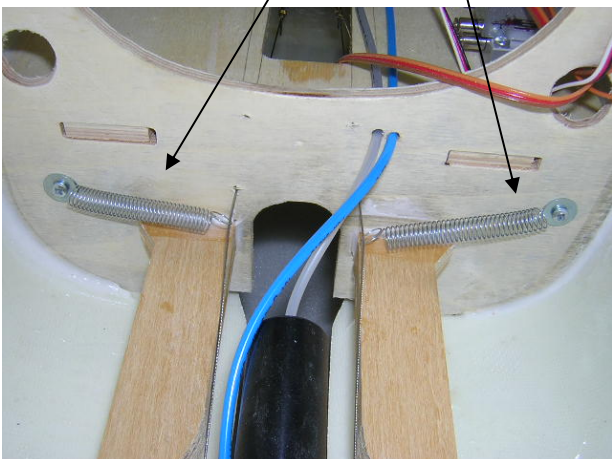

Stabs

Servos installation

Important : the servo MUST be a high quality servo, 8 kg torque, with metallic gears.
(It is also possible to use one single 8 kg torque servo for each stab)

Screw the 2 servos on the plywood mount

Connect the 2 servo arms with M3 link. We also recommend the use of aluminium servo a.rm

Test the 2 servos working together

The servo lead must be fixed to the fuselage and protected from engine.

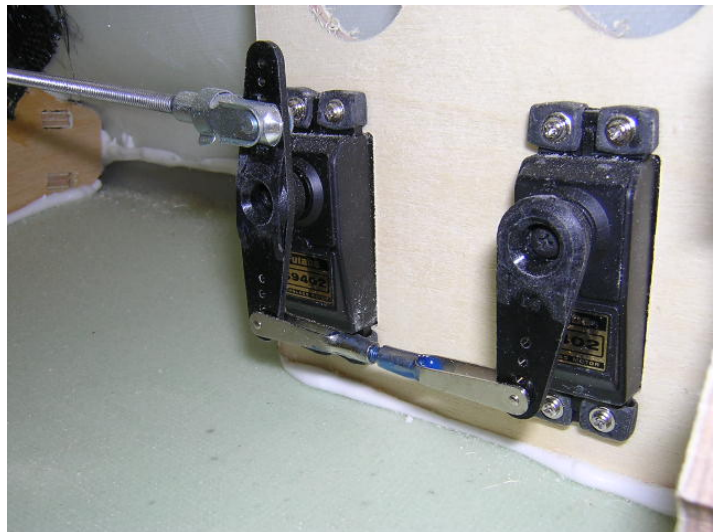

Ball link and control horn

Fit the ball link of the M4 threaded rod

Screw the ball link on the control horn with M3 screw and secure with blind nut



Stabs installation

Important : the 2 stabs **MUST** be balanced

The stabs are normally pre balanced at the factory. But we recommend to check if it is correctly done
When the stab is fitted in the tubing, it must be free in rotation : not hard point, no unbalance.

If necessary, you will have to drill a hole in the stab root and glue some lead in the leading edge to balance them.

Slide the plastic washer on the aluminium tube if necessary
so the stab don't touch the fuselage

Slide the stab in the tube.
Check again the clearance of the stab and the fuselage. The
stab must not touch the fuselage when it rotate.

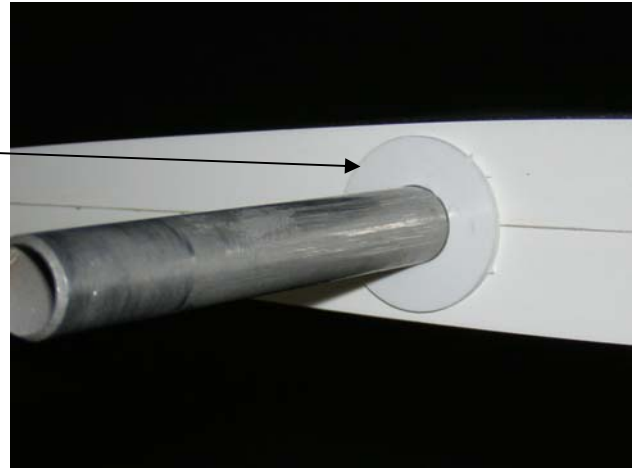

Slide the aluminium control arm on the tube. Insert a plastic
washer between wood and control horn.

Put the stab horizontal. Put the control arm vertical.
Screw and secure the 2 screws
Drill a 2.5 mm hole through the arm and through the aluminium
tube to secure it. Tapping it with M3 screw-tap.

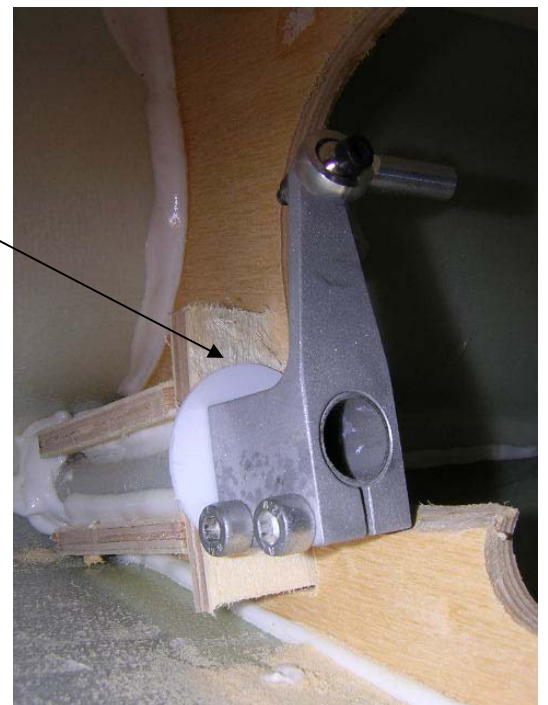

Connect the servo to the arm with the large M4 ball link and M4 threaded rod.
Glue them with threadlock.

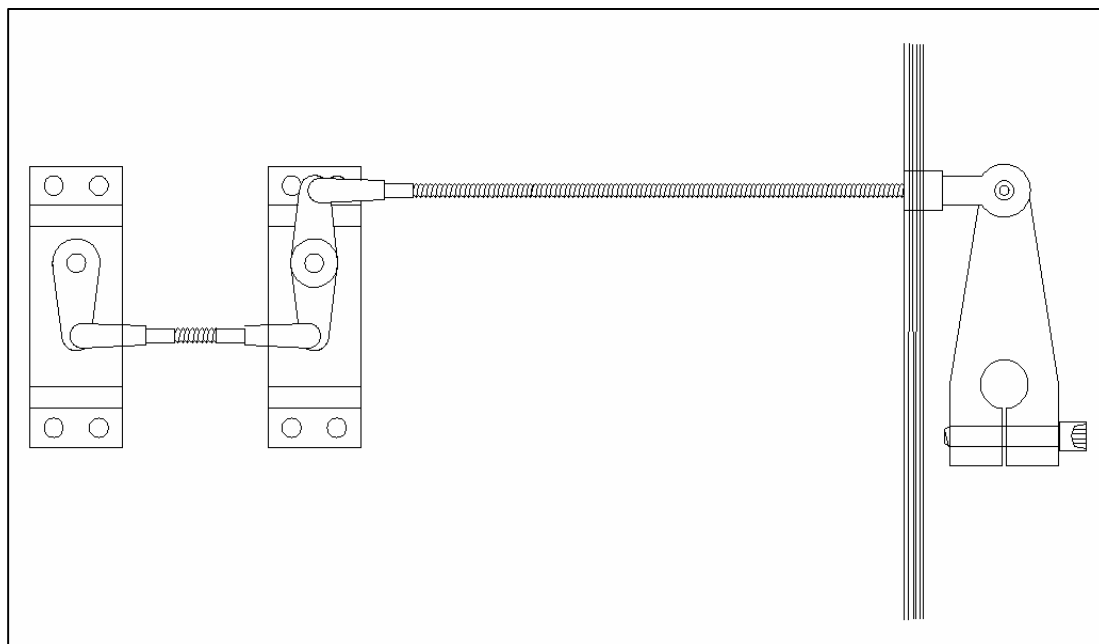
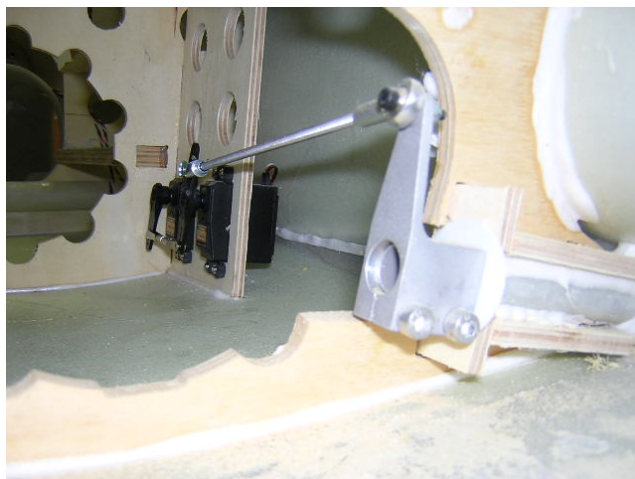
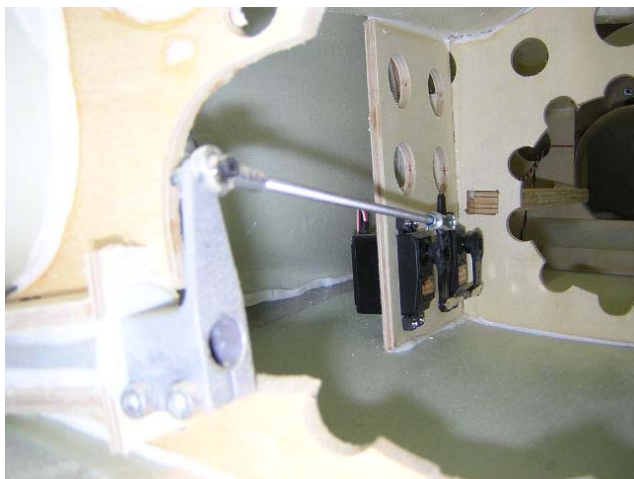

Aileron and flaps servos :

If necessary increase the hole for the servo location in the wings with a permagrit rotating tool for the aileron and flaps

Screw the servo in the servo cover (we recommand to glue it with silicon glue for more security)

Put in position the servo cover on the wings

Drill 4 x 1 mm hole in the wings for the screws

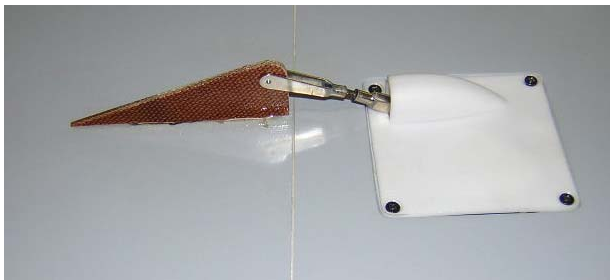

Cut a slot in the control surface for the fiber control horn

Glue with fast epoxy the control horn

Connect two 2 mm link with M2 threaded rod

Screw the servo cover with the 4 parker screws

Connect the servo with the control horn

Apply thread lock.

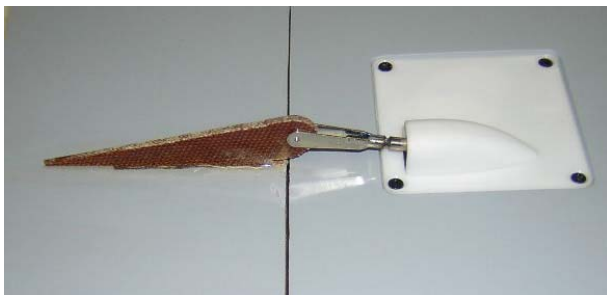

Aileron control horn

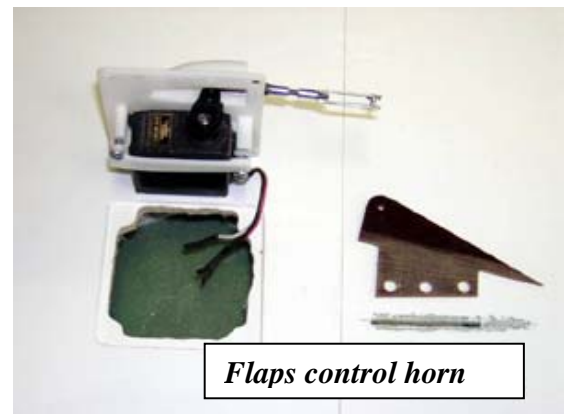

Flaps control horn

Make a 15 mm hole in the wing root for the servo electric wire
Don't make the hole too big so that the conector can't fall in the wing

Sold electric wire for the flaps and aileron



Make a 5 mm corresponding hole in the fuselage for the electric wire
Don't make the hole too big so that the conector can't fall in the fuselage



Wing pins

Sand half of the wing pins to glue them in the wings
Glue them in the wing with epoxy

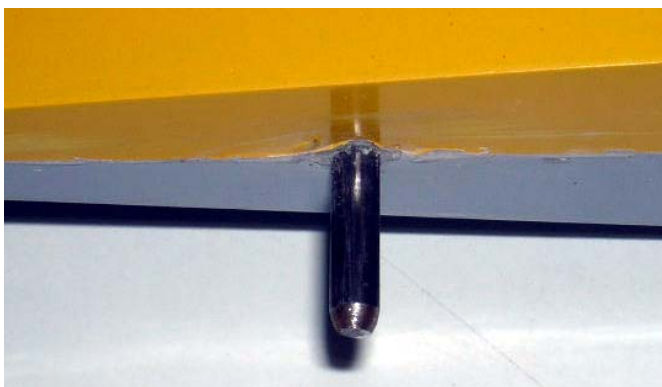

Secure the wings :

Fit the wing joiner tube through the fuselage.

Take care to put it at the center (same length left and right (about 300 mm).

Install the left and right wings.

Make a 2.5 mm hole at 250 mm from the wing root through the wing and aluminium tube to secure the wings (on the bottom of the wing, a plywood reinforcement is fitted)

Thread the wing tube and wing at M3 mm and secure wings with a M3x25 screw

You can also secure the tube in the fuselage, so the tube will not move during assembling and disassembling.

Make a 2.5 mm hole in the center of the fuselage from the engine hatch. Drill the hole through the fiber tube and aluminium tube to secure the tube.

Screw a 3 x 16 mm parker screw through the fiber tube and aluminium tube, so the tube will not move during assembling and disassembling.



Rudder servos :

Process as the wing servo :

Increase the hole for the servo location in the booms with a permagrit rotating tool for the rudder

Screw the servo in the servo cover (we recommend to glue it with silicon glue for more security)

Put in place the servo cover on the fin

Drill 4 x 1 mm hole in the wings for the screws

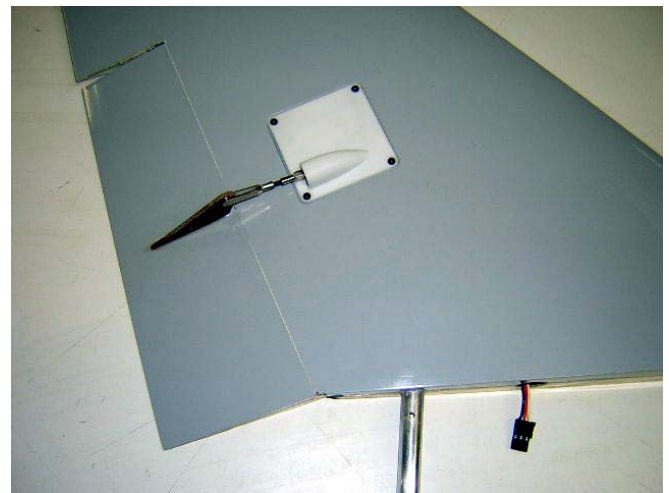
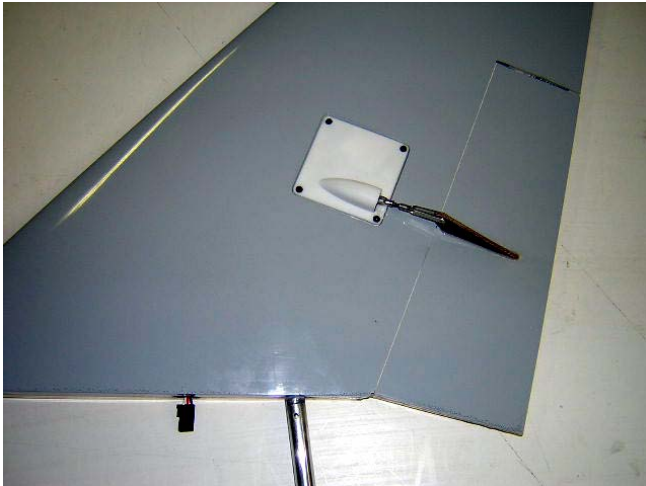

Cut a slot in the control surface for the fiber control horn

Glue with fast epoxy the control horn

Connect two 3 mm link with M3 threaded rod

Screw the servo cover with the 4 parker screws

Connect the servo with the control horn

Apply thread lock.



Make a 20 mm hole in the fin root for the servo electric wire.



Make a 5 mm corresponding hole in the fuselage for the electric wire. Don't make the hole too big so that the connector can't fall in the fuselage.

Sold electric wire for the 2 rudder in Y



Secure the fins :

Fit the fins on the fuselage.

Make a 2.5 mm hole at 15 mm from the fin root through the fuselage and aluminium tube to secure the fins. Thread the tube and fuselage at M3 mm and secure fin with a M3x15 screw.



Fuel tank

Connect the fuel tank to the clunk as the photo.
Check that there is no leak before to fit it in fuselage.

Drill a 3 mm hole in the bottom of the fuselage for the fuel vent

The fuel tank is connected to the small catch tank (200 cc) or UAT catch tank to be sure that there is no bubble in the fuel line.

The tubing from the main tank to the catch tank and to the catch tank to the fuel pump must be gasoline tubing (no silicone tubing). Also for the air vent tube.

The catch tank is glue with double face tape or with rubber band on the top of the main tank.

Hold the fuel tank with rubber bands or silicon glue

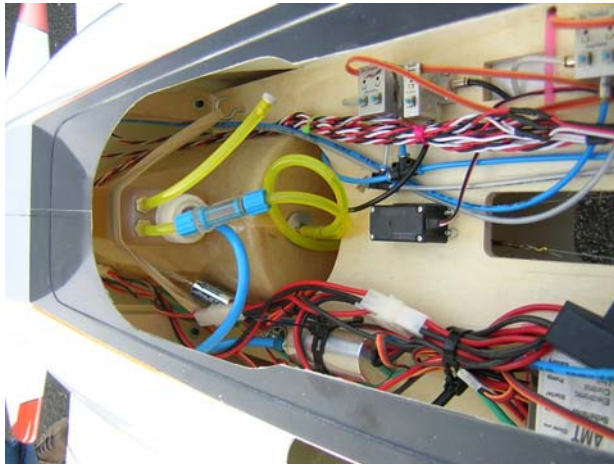

Filling the fuel tanks :

Connect your pump and fill the system in direction of the tank. It will first fill the catch tank and after the main tank. The main tank will be full when fuel come from the air vent tube.

When tanks are full, close the filling tubing.

Do not close the air vent tube after.

The system is ready for starting.

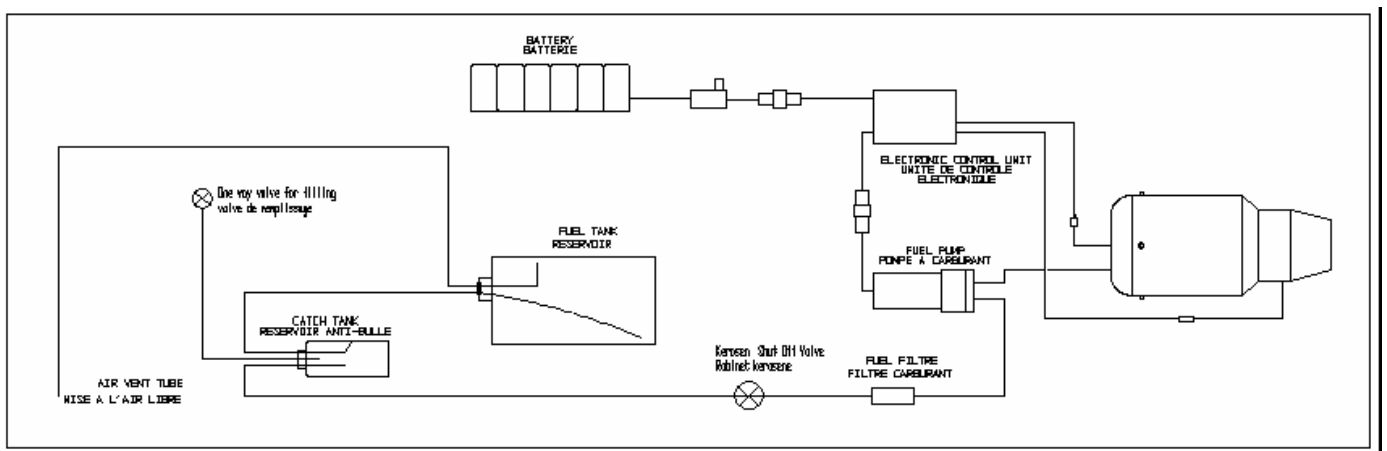
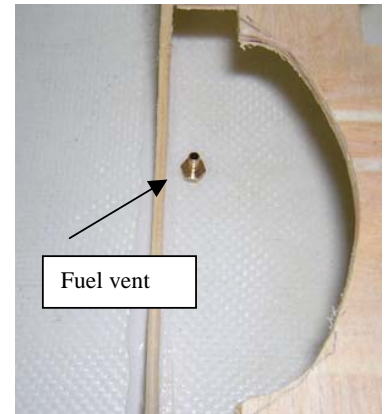

STEEL TAILPIPE EXHAUST

Fit in the fuselage the tailpipe from the fuselage hatch.

Tailpipe will be screw on the rear engine frame with 3 x 3 mm diameter parker screw at 120°

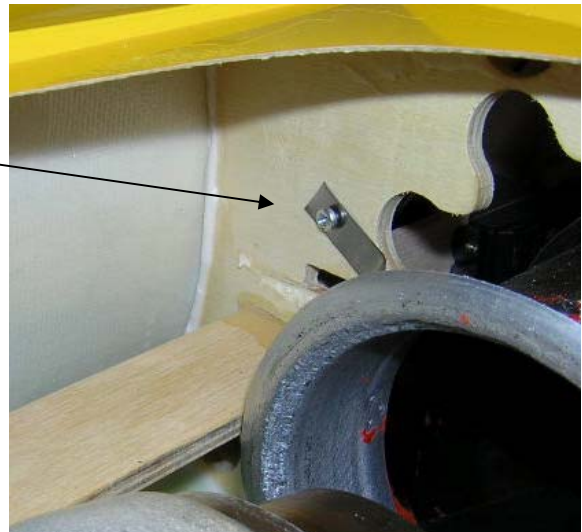
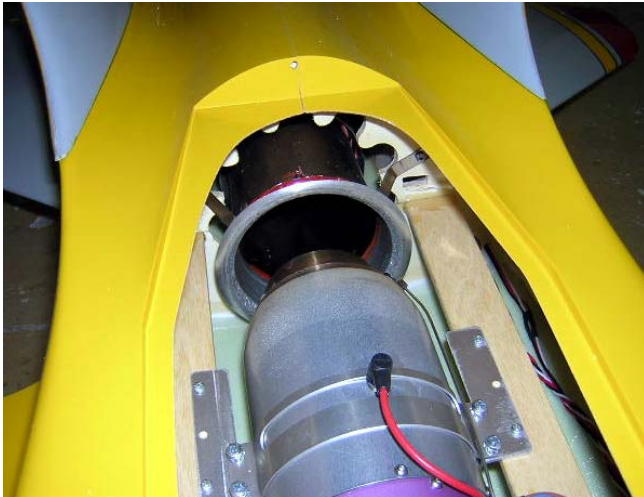

Fiber Exhaust cone :



Glue with CA a 6 mm wood pins on 2 opposite sides of the exhaust cone

Drill the 2 corresponding 6 mm hole in the rear fuselage



Screw the tailpipe with 2 x 2mm parker screws to secure the wood pins



Engine installation :

If necessary, cut a hole in the inlets for the electric starter location



Adjust the position of the engine / beginning of the exhaust tube
The engine must be screw with 4 times 3x20 mm parker screw to the rear position.
Secure all electric wire and fuel tubing in front of the engine in the fuselage



ECU installation :

Fit the ECU in one side of the plane.

Fit the fuel pump and valves just rear to the ECU and hold them with T rap.

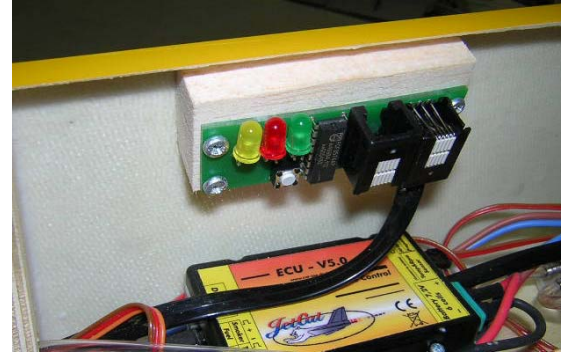

Gear valves, air tank, batterie, antenae

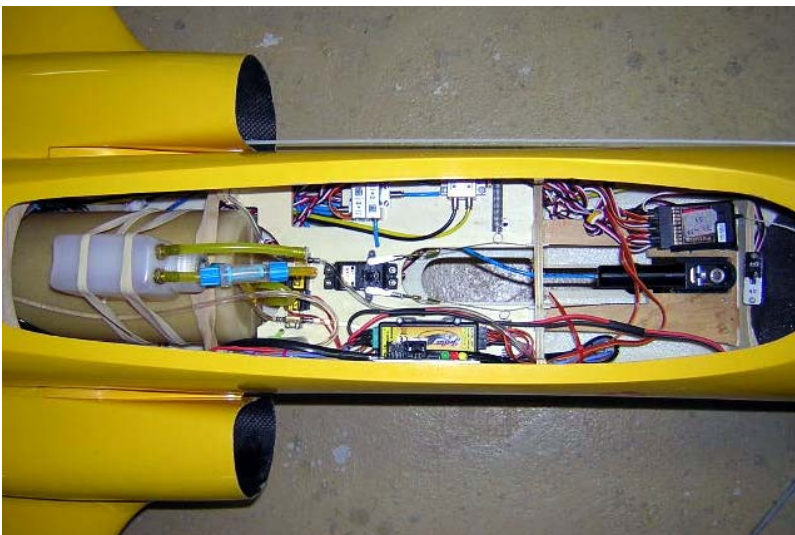

Fuselage hatch:

Make a 6 mm hole in front of the fuselage hatch for the 2 wood pins.
Glue the wood pin with CA in the hatch

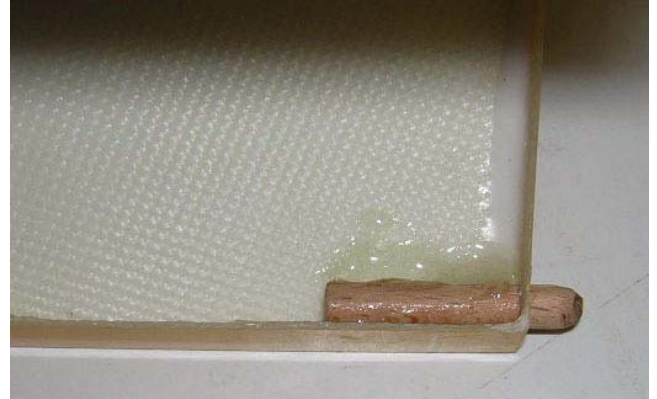

Glue the wood pin with CA in the hatch
Drill the corresponding hole in the front fuselage

Cut a slot and make a 3 mm hole in the back of the hatch for the hatch latch

Glue the hatch latch with CA. Take care to not glue the metallic part
Fit the hatch on the fuselage and draw the corresponding hole

Drill the corresponding hole in the fuselage



Fitting the dorsal air brake

Fit robart hinges in the 2 aluminium tube

Glue the 2 aluminium tube with CA on the airbrake. Take care that the hinge point is at the air brake limit (see pic)



Glue the 2 Robart hinges in the tube with epoxy. Bend the hinges at 90° to be sure they are parallel



Screw the 2 plywood horns on each side of the cylinder rod with the M3x16 screw and nuteated rod in the air cylinder rod

Glue the plywood horns in the center of the air brake as the pics.
Axis of the link must be at 200 mm from the end (see pics)

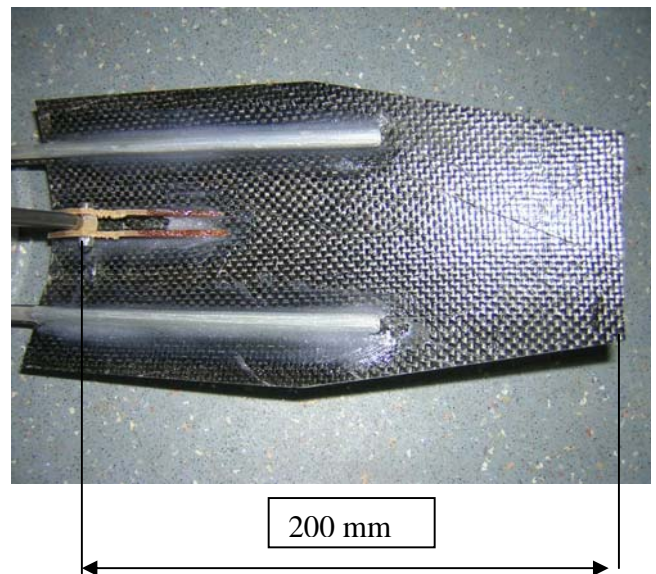

Fit the 4 mm threaded rod in the air cylinder end
 Fit 2 M4 screws to lock the air cylinder in the middle of the threaded rod. Secure the screws

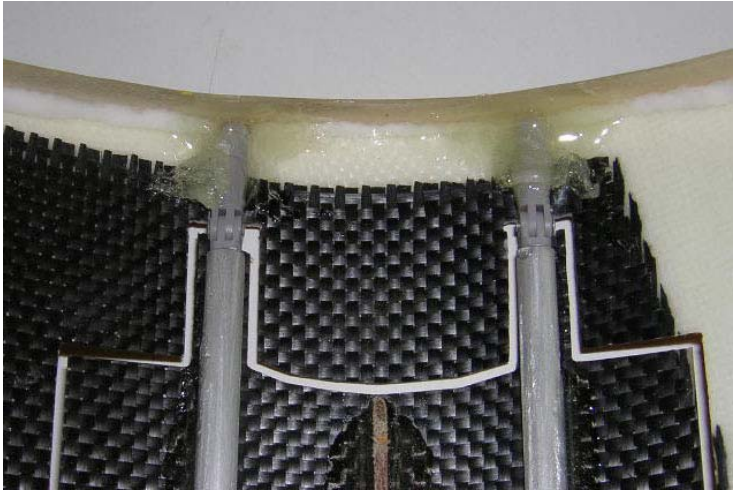

Cut the end of the hinges to fit in the fuselage hatch

Send the 2 air brake pads with an angle so that the air brake can open and closed without problem (see pics)

Glue the 2 hinges on the fuselage with CA. Take care to not glue the axis (put oil on it).

Take care that the airbrake is perfectly centered in the hatch

Secure the hinges with epoxy

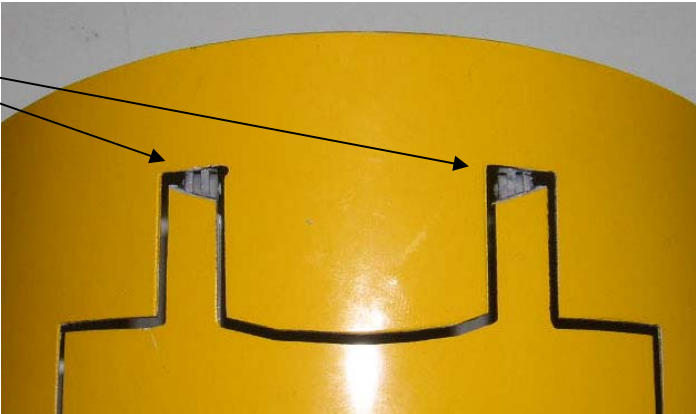

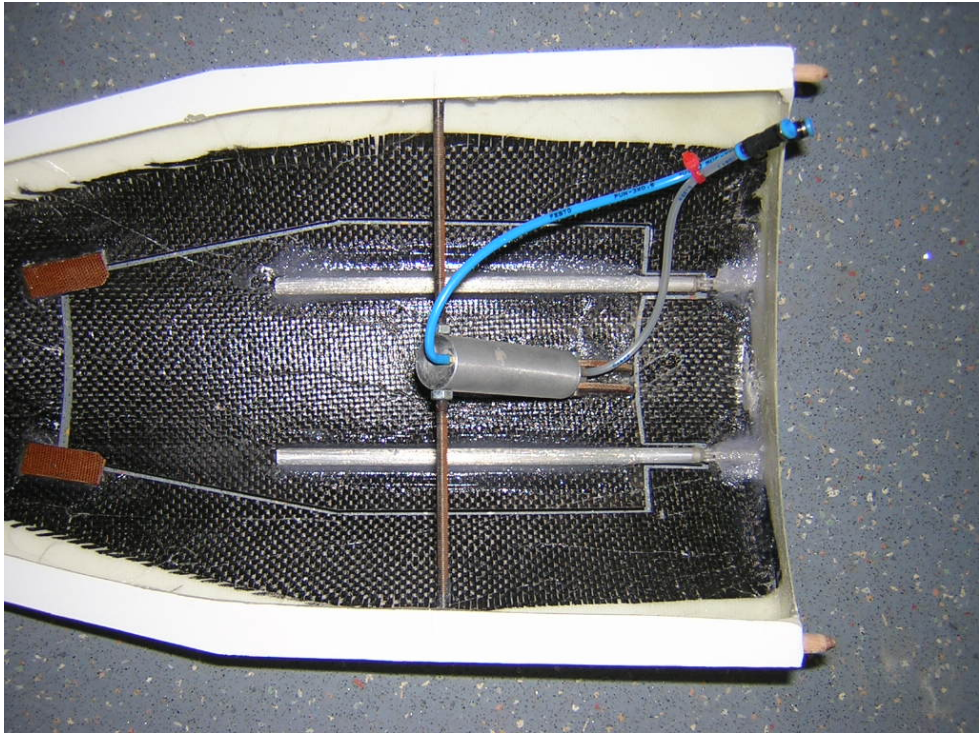

Adjust the position of the that the air cylinder is fully closed when air cylinder is closed and open with cylinder open. Distance is approximatly as the drawing

120 mm

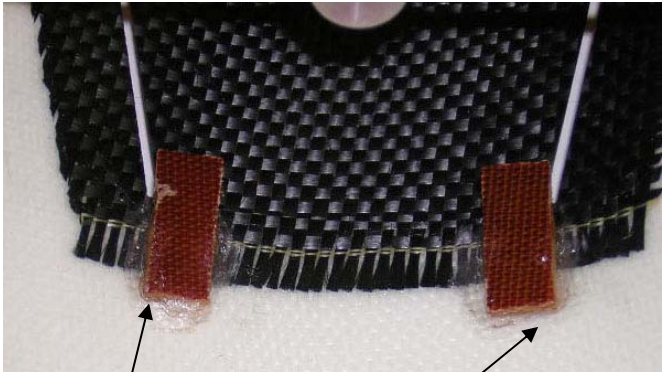

Glue 2 pieces of fiber or plywood at the end of the air air brake hatch to have a air brake stop

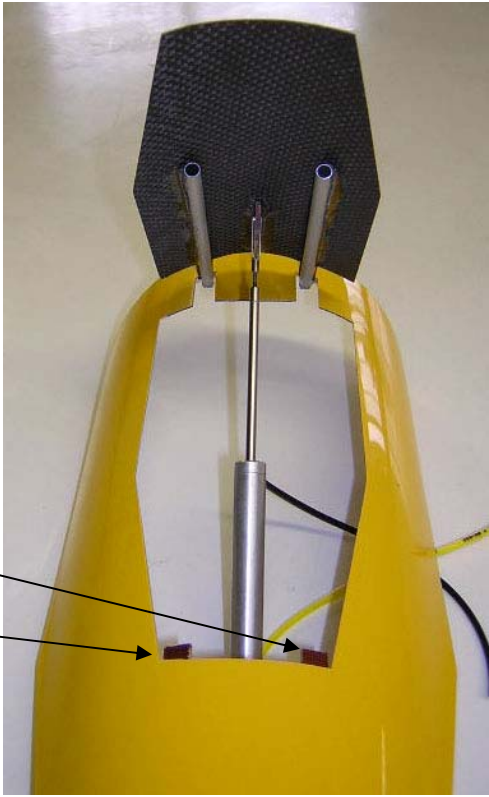

Canopy hatch:

If you choose to not fit clear canopy just follow the next step.

Make a 6 mm hole in front of the fuselage hatch for the wood pin.

Glue the wood pin with CA in the hatch
Drill the corresponding hole in the front fuselage

Cut a slot and make a 3 mm hole in the back of the canopy for the hatch latch



Glue the hatch latch with CA. Take care to not glue the metallic part
Fit the hatch on the fuselage and draw the corresponding hole
Drill the 3 mm hole in the fuselage



Clear Canopy

If you choose to fit the clear canopy, follow the next steps :

Cut the fiber canopy as engraved on the canopy



Glue the 2 plastic vacuum parts in the fiber canopy frame

Paint all the internal parts in black



Cockpit detail kit :

The first step is to assemble the ejector seat :

Cut the vacuum parts as shown

Glue with CA the 2 vacuum parts and the 2 plastic parts according to the plan.

Drill a hole in the ejector seat head to fit the plastic horns.
Glue it with CA

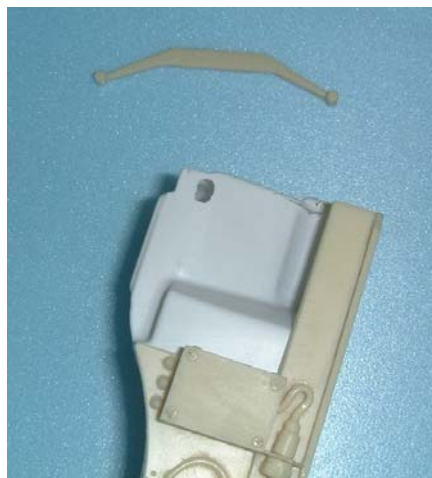
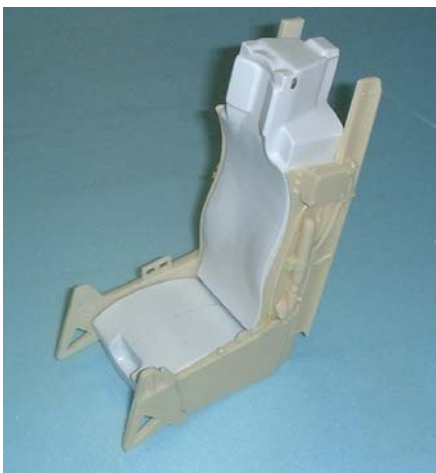
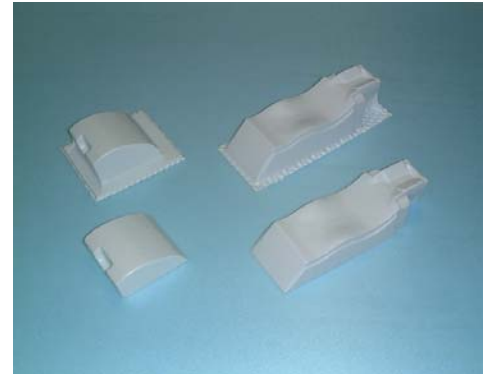

Glue with CA the plastic part at the rear of the ejector seat.



The second step is to cut the pilot foot and the pilot backside.

The third step is to fit all the part in the cockpit vacuum part

Fit the ejector seat in the ABS vacuum part.

Fit the pilot and instrument panel.

You should have to heat the pilot (with a air gun heater) to fit it in the cockpit with the good angle and to slide the instrument panel between its legs.

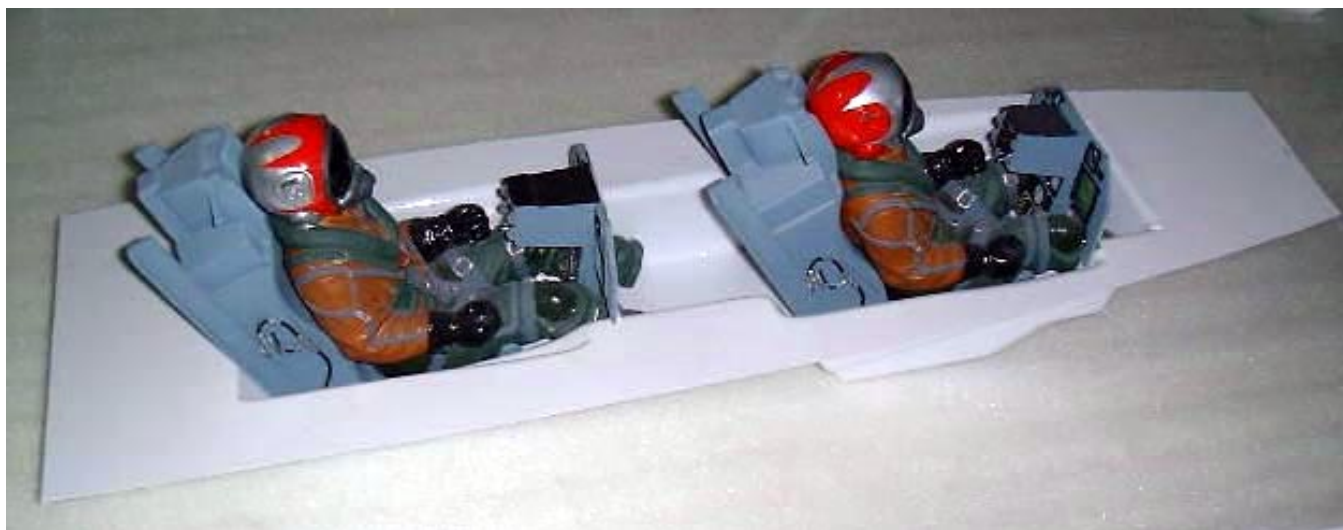

If everything is OK, you have to paint all the parts first before to glue them.

Glue the ejector seat in first.
After glue the pilot.

Radio installation :

Fit the radio in the nose section with batterie.

Adjust batterie position to have to correct CG position.

Don't put the receiver and aerial antennae too close the the ECU

Retract valve and brake valve can be fitted as the pics

We also recommand the use of a Power box system or similar system required for the big number of high torque servos

Recommended surface throws

Ailerons

Up : 25 mm Down : 25 mm Exponential: 10

Rudder

20 mm left and 20 mm right Exponential: 10

Flaps

25 mm down with also mix 5 mm up elevator for pitch down moment

45 mm down with also mix 10 mm up elevator for pitch down moment

All measured in the widest part of the surface

Elevators

Up 50 mm Down 30 mm Trim : 12 mm up Exponential: 10

All measured at the trailing edge of the stab

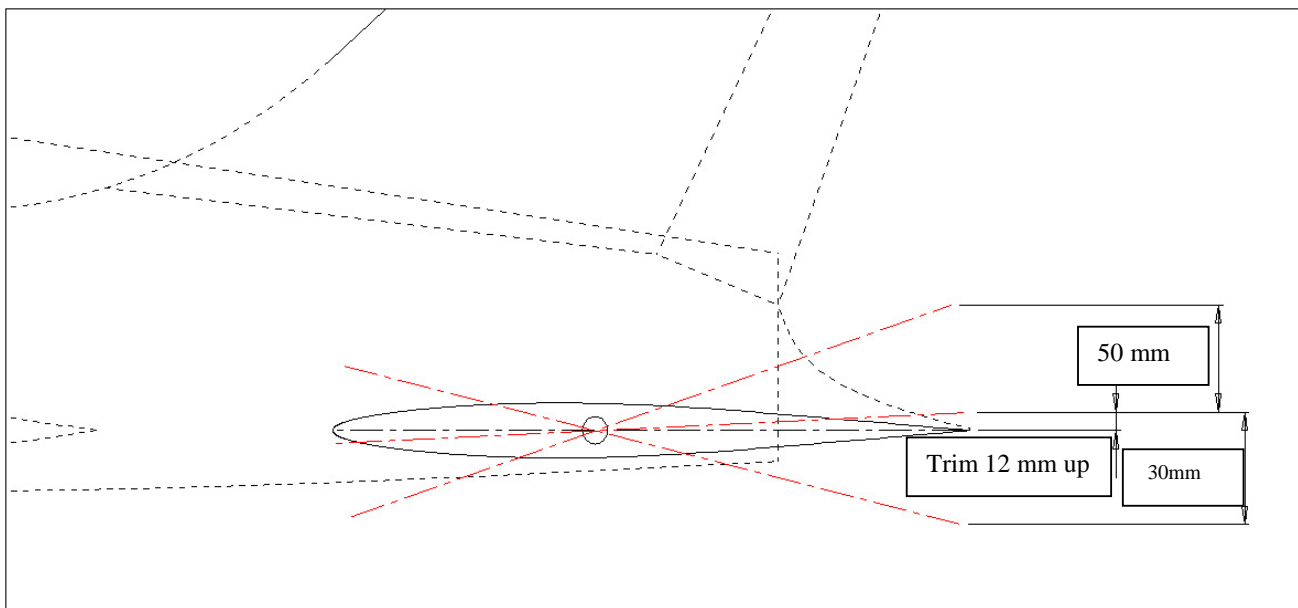

Center of gravity

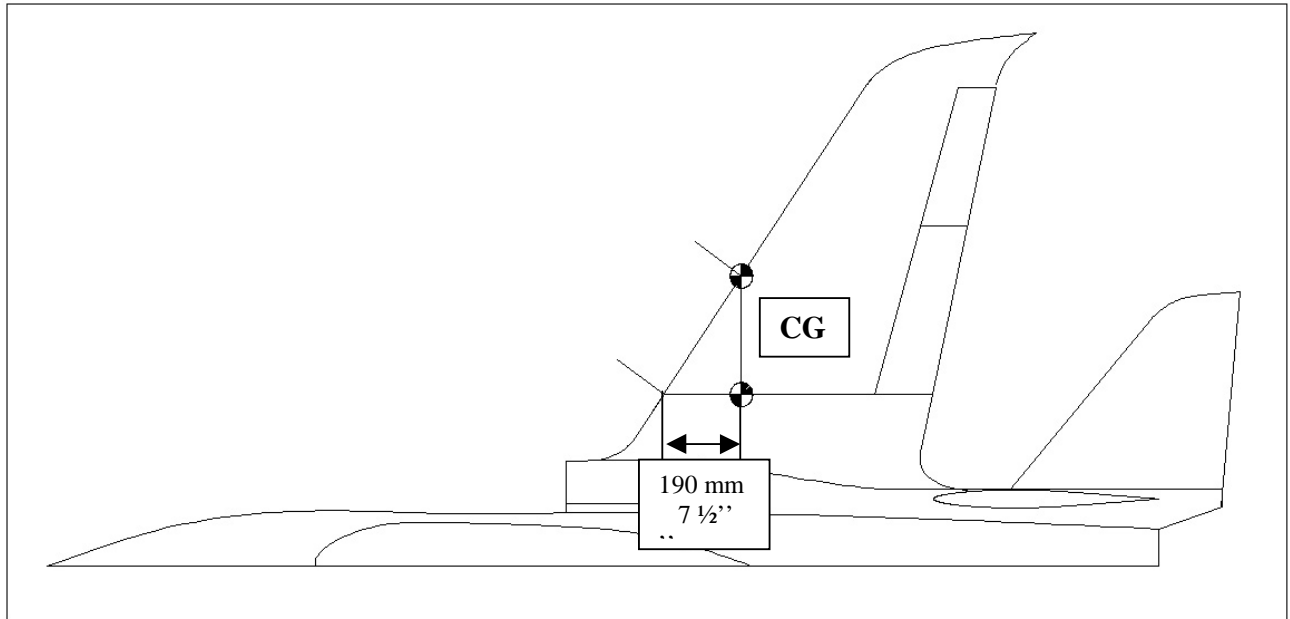

You normally need 2 x 1700 Mah battery + ECU battery in the nose to have a correct Centre of Gravity.

Note : balance the model with the gear down and the tanks empty.

The center of gravity (CG) must be located at 190mm rear of the wing leading edge (wing root)

You must check it before the first flight, to do this with the aircraft in flight condition but without fuel lift the aircraft in this point, the aircraft must adopt a horizontal attitude. If the tail drops move the batterie forward or add weight in the nose.

In other hand if the nose drops considerably add weight in the tail.

Total weight

The total weight of the **SUPER SCORPION** is 17 kg tanks empty.

Important note : Pay very careful attention to structural integrity. This jet can reach speeds of over 400 KPH - 250 MPH. It is your responsibility to operate it safely.

Specifications may change without notice.

[

*Gabarit de trappe de train
Gear door template
for behotec gear*

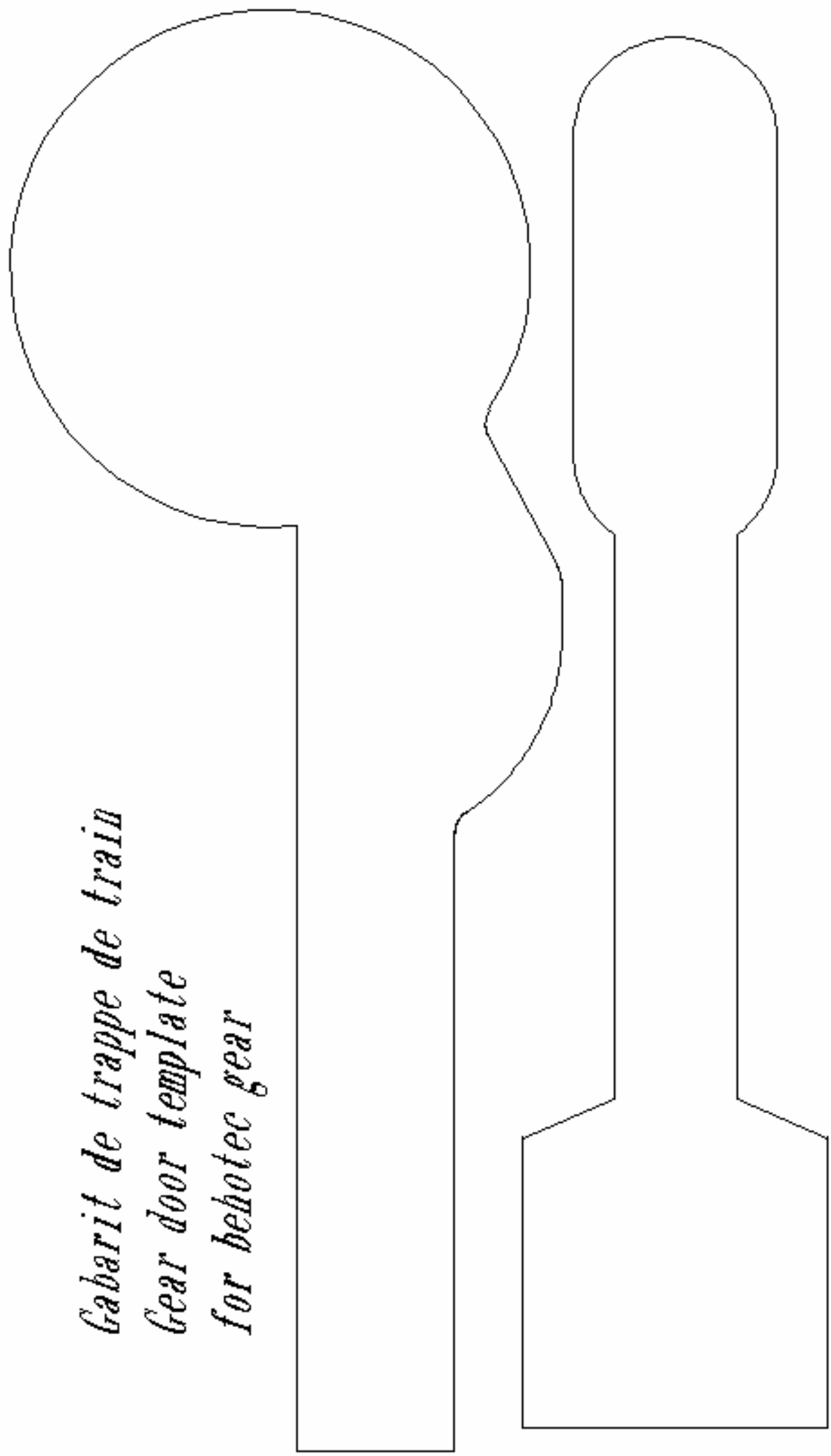

] 31