

BUILDING INSTRUCTIONS

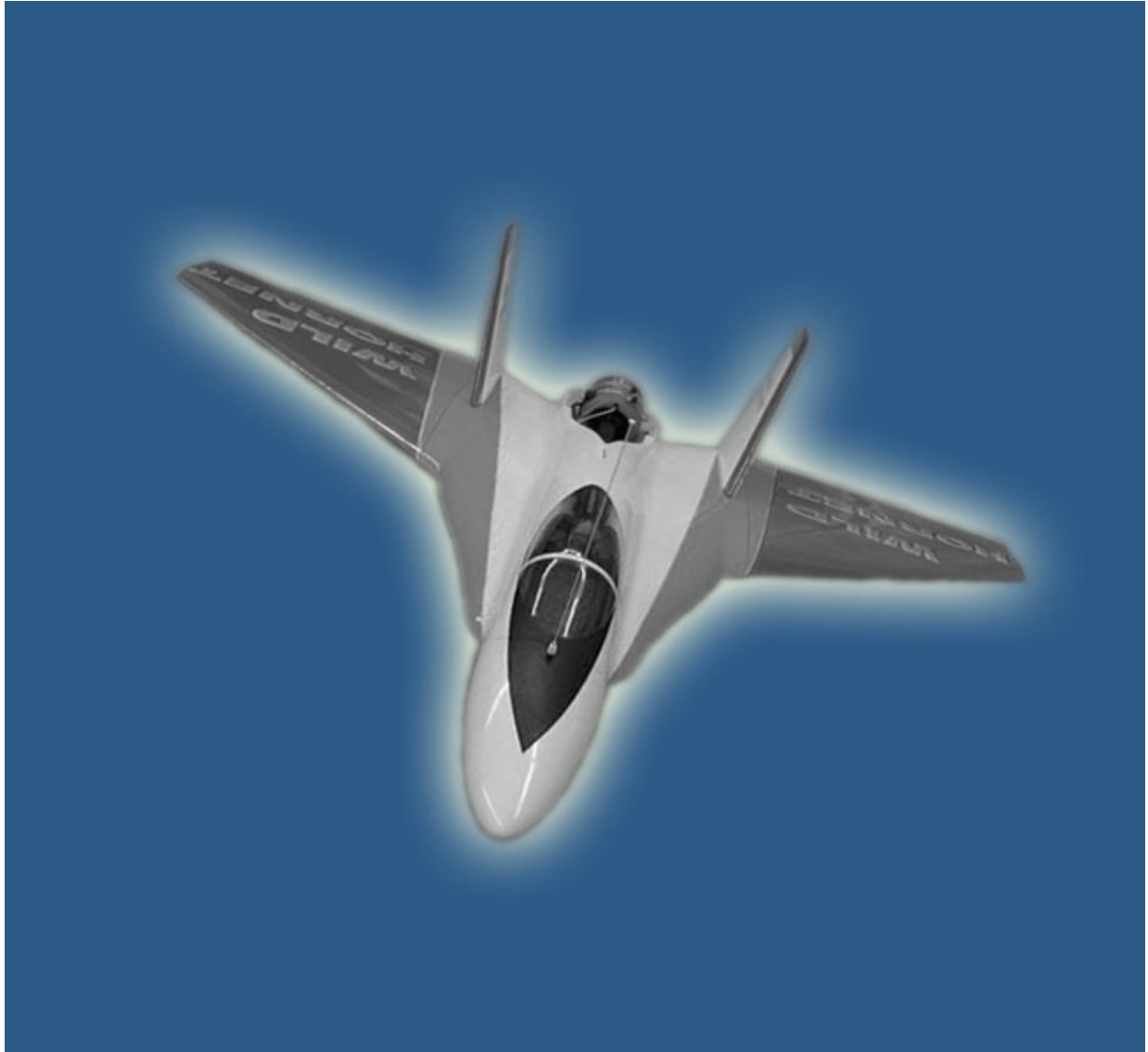

LIST OF PARTS

WILD HORNET

Variant "A"

- 1x white laminate body
- 1x laminate cover of the body
- 1x clear cover of the cabin
- 1x pressed piece of the cockpit
- 1x two-part pressed piece of the seat
- 1x look-through display
- 1x set of self-seal labels – the cockpit equipment

- 1 pair polystyrene-balsa wings
- 1 pair poly-balsa direction indicators
 - 1x duralumin beam tube (92.5cm)
 - 1x braking shield

- 1x set of milled partitions
- 4x milled holders of aileron servos
- 4x wing pins
- 12x aileron hinges pins
- 4x laminate covers of the aileron servo
- 4x aileron laminate levers

- Small parts**
- 6x cabin pin
- 5x servo pull-rod
- 2x screw Imbus M4x30 – wing securing
- 4x screw Imbus M4x12 – direction indicator securing
- 4x wood screw 2.5x10
- 16x wood screw 2.5x12 - servo covers securing
- 10x servo fork
- 4x direction indicator pins

- 4x braking shield hinge
- 12x aileron hinge

- 1x PET bottle, 2 litres

Assembly bands of the tank, pump and valves



Thank you for showing your trust and purchasing the building-block system Wild Hornet. The model is produced using modern technology – vacuum degassing of the body sandwich construction. In production and completing of the building-block system, we have been particular about the maximum possible accuracy of the parts. Also, the pre-milled partitions are produced in such a manner so that it is as easy for you as possible to assemble the model. When the inner construction of the model is done according to the instruction, there is no need to worry about the centre of gravity!, to be adjusted in the end only by subtle shifting of the accumulators in the body.

We believe that finishing of the model shall bring the same kind of joy as your experience from the flying itself. We wish you a lot of fun and especially that the number of landings is the same as the number of take-offs...

JETARROWS

Contents:

| Chapter | Page |
|-------------------------------------|------|
| List of Parts | 1 |
| Technical Parameters | 4 |
| I. The Body and the Cockpit | 5 |
| II. The Inner Construction | 6 |
| Partition Scheme | 9 |
| III. The Aerodynamic Brake Assembly | 10 |
| IV. The Undercarriage | 10 |
| V. Wings | 11 |
| VI. Direction Indicators | 13 |
| VII. Model Equipment | 13 |
| VIII. Model Adjustment | 14 |
| IX. Flying | 14 |
| X. Safety Instructions | 15 |



For those modellers who do not like to read through long building instructions or are experienced in model building, we have several shorts tips:

1. Try not to increase the model weight too much during the construction. The lighter your HORNET is, the better flight properties it shall have, especially in case of minimum flight speeds.
2. Glue consistently the rudder suspensions and aileron levers, preferably with a laminating epoxide with microballoons and crushed cotton.
3. Use exclusively metal forks for the control pull-rods (they form a part of the building-block system).
4. It is unconditionally necessary to observe the prescribed strength of the aileron control servos!
5. Upon every landing, check the undercarriage condition and straighten possible deformations, this prevents possible non-lowering of the undercarriage and belly landing.
6. Wild Hornet reaches high speeds (it commonly flies at speeds exceeding 300km/h), therefore fly only when you are convinced about proper functioning of the control device.
7. Use double receiver accumulators.
8. Keep in mind that in case of an accident, a property damage or injury can occur. Therefore do not overestimate your art of flying nor perfect functioning of the electronic equipment. Do not fly above people or in a built-up area.



Technical parameters:

| | |
|-----------------------|---------------------|
| Length | 1620mm |
| Wings span | 1660mm |
| Mass | 8 kg (without fuel) |
| Areal load | 86g/dm ² |
| Number of channels | 8 |
| Controlled functions: | aileron |
| | elevator |
| | engine |
| | bow wheel |
| | aerodynamic brake |
| | undercarriage |
| | brakes |
| Min. speed | ca. 25 km/h |
| Max. speed | 400km/h |
| Tank | 2l |

Recommended fitting of the model:

| FUNCTION | EQUIPMENT | PARAMETERS |
|-----------------------|----------------------|-------------------------------|
| Ailerons | 4x Futaba 9206 | min. 8kg |
| Braking shield | 1x Futaba 9202 | min. 5kg |
| Receiver accumulators | 2x5 cells | 1100mA/NiCd |
| ECU accumulators | 6x1400mA/NiCd | or as the producer recommends |
| Undercarriage | Eurokit or Jetarrows | for models up to 12kg |
| Receiver aerial | Graupner, bar-shaped | |



BUILDING INSTRUCTIONS

Check whether the building-block system is complete according to the list of parts.

I. The Body and the Cockpit

At first, clean all burrs on the body which occur during the laminating process, especially at the place where the upper and lower halves of the body are to be connected. Check and possibly clean the openings for the beam tube and for the securing pins of the wings and ailerons. Afterwards clean the cabin laminate cover, cut off the redundant laminate (preferably using a diamond disk) along the cutting line on the cabin overlap. Upon grinding of sharp edges, check and possibly gently match the perspex overlap of the cabin (small irregularities will be successfully hidden subsequently by the inserted cockpit). Cut the pressed piece of the cabin cockpit and of the seat. Here the cutting line is visible, as well. It is suitable to complete the seat rest with a balsa little plank having the thickness of 2 mm. Glue the seat into the cockpit using the second glue. Now fasten the edges of the triangle projection on the front part of the cockpit with a self-seal band and cut out carefully, at a low angle, using a saw, a slip for placement of the HUD (the look-through display), made of the enclosed piece of smoked perspex. This piece is to be glued, upon its spraying, in the cockpit at the bottom side using the second glue or a glue for gluing of PVC materials.



We recommend to spray the cockpit using the dark-gray, matte colour TAMYIA TS-48 for plastic models.

Upon gluing of self-seal labels of the deck boards, the cockpit is ready to be connected with the body cover.

The cockpit can be glued to the cabin using a thin double-sided adhesive tape or "permanently" using a glue.

Roughen the perspex cabin edge from both sides using emery paper and **put the medium-dense second glue at separate spots carefully on one half only. Proceed with care so that the glue or the activator do not damage visible parts of the cabin.** When everything is fitted properly, glue the edges carefully using the second glue and apply a little of the activator spray. Then glue the cockpit to the whole unit. The cockpit must be glued along its whole circumference so that no dust can get inside in the future.

ATTENTION! Proceed carefully at this point and check whether the cover fits the body and has not curled up! If you glued firmly the cockpit with the cabin in advance, the whole set might not fit precisely the laminate cover of the body. By observing the procedure described, you can avoid subsequent problems in fitting individual parts.

Finally attach the metal pins 3x30 mm enclosed in the model set, from the front side into the openings in the cabin frame and 4 pcs of the metal pins 3x20 mm from the bottom side. The openings in the cabin and in the body are made already. In order to obtain a better function of the cabin securing, it is suitable to redrill the body for the diameter of 3.2 mm. For the purpose of gluing, to fix the position use a drop of the second glue and then an epoxide with cotton.

Securing of the cabin – mill out two cuts having the width of 3 mm in the edge of the turbine bed and drill out an opening in the oblique direction. Pass the plastic tube (the modeller's Bowden cable) through the openings prepared in the partitions and secure it with a glue. The inner teflon insert with the steel wire is to be passed-through inside and bent at the end in the angle of ca. 90 degrees. Afterwards, paint the Bowden cable end with a black marker, fit the cabin and print the colour onto the cabin frame. Upon the drilling out, the cabin is perfectly fitted and secured.

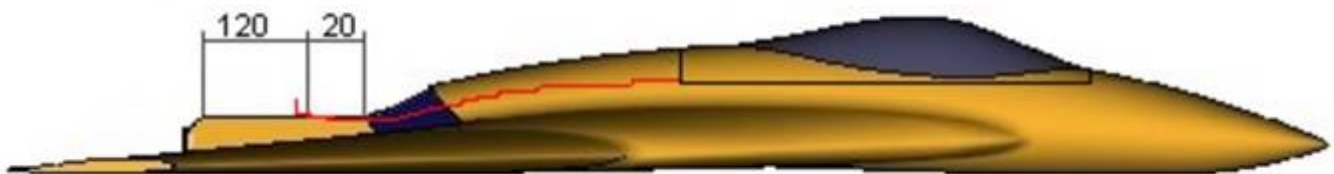

II. The Inner Construction

The building-block system is supplied with plywood parts. These parts are milled out, including the openings for gripping of the braking shield servo, of the turbine fuel pump and of the fuel and gas valves. The inner installation has been designed for the turbine engine JetCat P80 and when the layout of individual elements is observed, you shall not have any problems with the model centre of gravity. However, we believe that even in case other engines are used, balancing of the airplane shall be easy upon making fine changes. Clean the milled out plywood parts, fit them together and glue them into the body according to the figures.

Tip! As a glue, we recommend to use the laminating epoxide mixed with microballoons and cotton. Using a syringe and a little hose, you can manage to get this glue to all the places where it is needed.

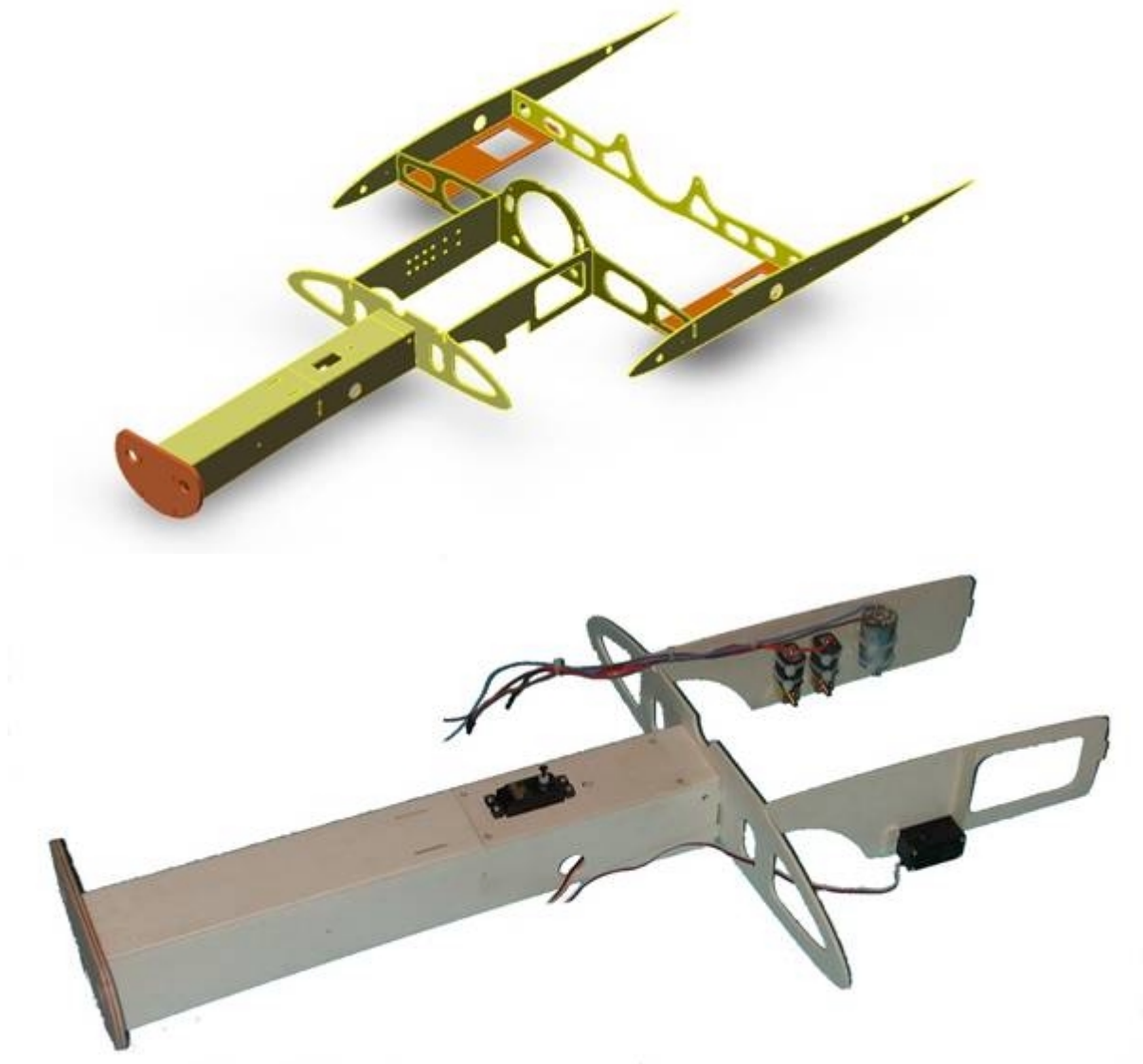

Upon checking loose the partitions in the body, fit the partitions as follows:
Slide two sides in the front rib and fit the second rib. Insert the separation partition of the undercarriage and slide on it from top the stiffener made of hard plywood. Insert the stiffener at the second rib and glue everything using the second glue, except for the second rib. Otherwise you shall not be able to place the unit into the body! Now glue the covering plywood in the front and at the end of the tunnel. Glue the stiffener for the servo screws onto the plywood of the control servo of the front wheel.

Using the second glue, fasten stiffeners for screws of the braking shield servo into the partition. Check whether it is possible to insert the servo into the opening and prepare openings for the servo screws.

Insert the unit set up in the manner described into the body and check everything once again. The partitions should not touch too tightly the body anywhere in order not to be printed on the model surface. Gaps shall be filled with the epoxide.

Then glue using the second glue the tunnel with the second rib and with partitions for the shield, valves and turbine pump servo. Subsequently, glue the whole set up unit to the body using the epoxide with cotton and microballoons (ca. 50/50).

We recommend to stiffen the front partition using the carbon fibre.

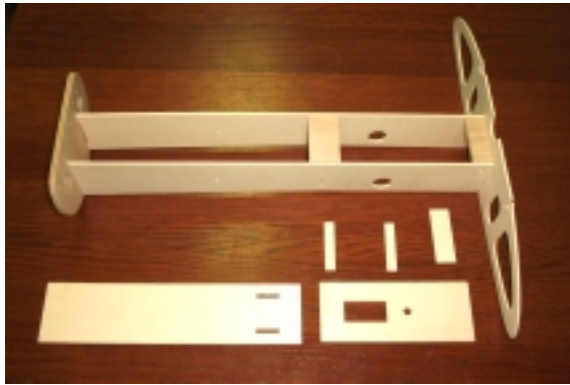



Now set up the undercarriage bed. Cut out openings into the body for the undercarriage. Again, set up loose the plywood stiffener and the undercarriage sides. It must be possible to slide gently plywood, thickness 0.8 mm, under the sides. This plywood shall prevent printing of the sides into the upper Hornet covering. Insert the undercarriage, mark openings for screws and drill everything together using the drill 1.5 - 2 mm.

Apply the epoxide thickened with cotton on the plywood board and put it, from inside, onto the upper side of the laminate. Apply the glue on the plywood stiffener and the sides and put everything together. In the end, screw everything together using small wood screws.

The inner construction of your Wild Hornet is now finished.

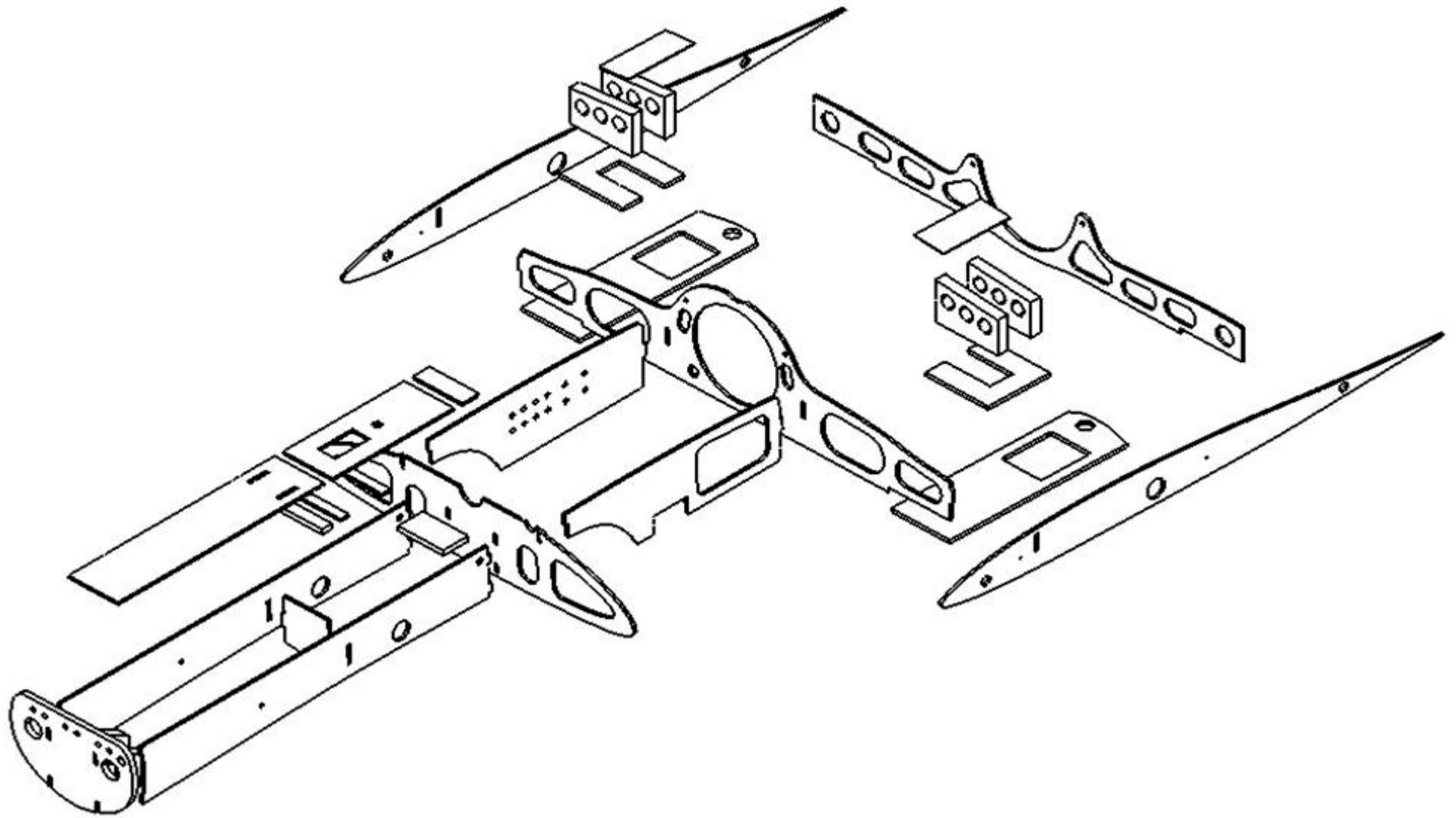

III. The Aerodynamic Brake Assembly

Check the laminate braking shield enclosed whether it copies the shape of the body, possibly heat it with a hot-air pistol (a hair dryer) and fasten it back using an adhesive tape. Upon its cooling, take it out and cut 4 openings into the body for the brake suspensions. Roughen the hinges and glue them, preferably using the glue Flex Zap or the 30min. epoxide. Fit the flap in the slot so that a gap remains in the front, in the width of about 1.5 mm, and secure it with the band. Subsequently glue the suspensions onto the flap, as well.

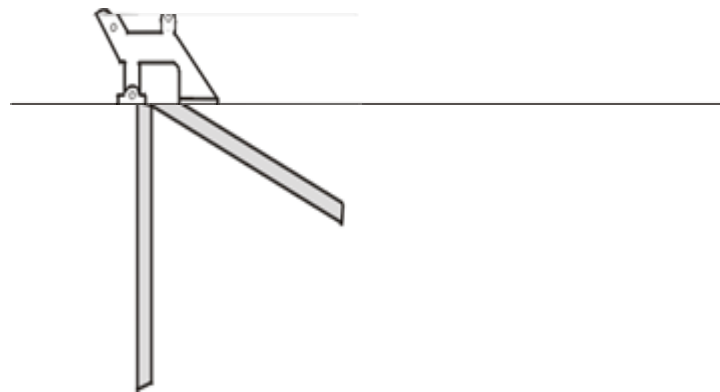
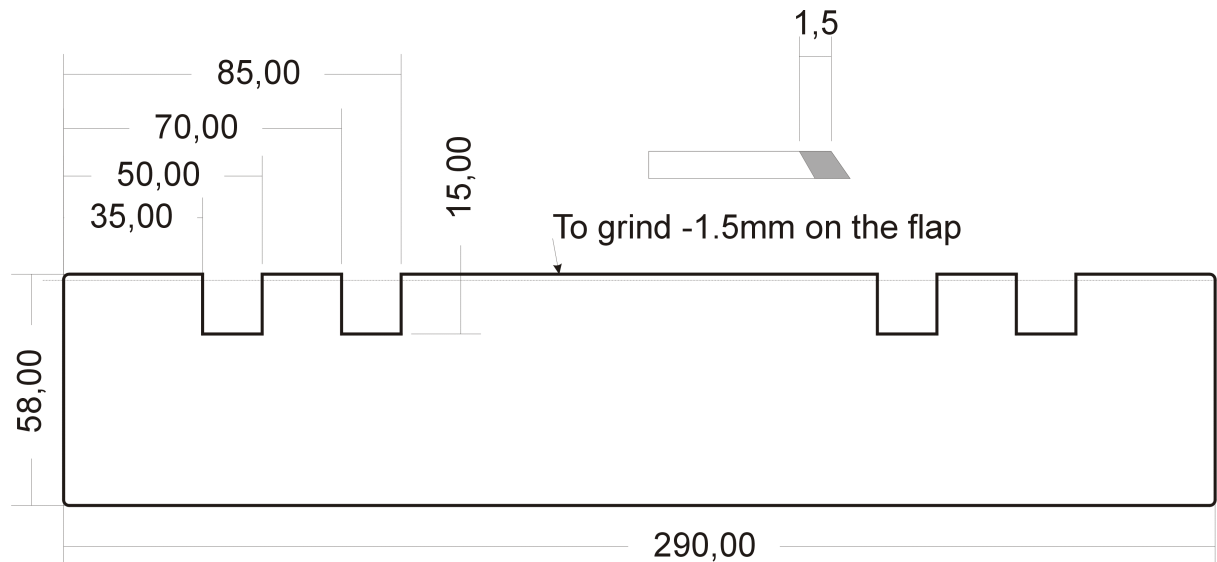

IV. The Undercarriage

If you used the undercarriage supplied by us, fit it in the body in the openings prepared according to the previous chapter.

The bow mechanism is installed in plywood little triangles, however, it is good to grind a part of the undercarriage shaft edge in advance, which serves as the contact area of the undercarriage door (the undercarriage door does not form a standard part of the building-block system).

V. Wings

Using a heated steel wire (having the diameter of e.g. 6 mm), make an opening in the wing for the servo cable, see the figure.

Tip! Mark the course of the channel on the wing using a covering band.

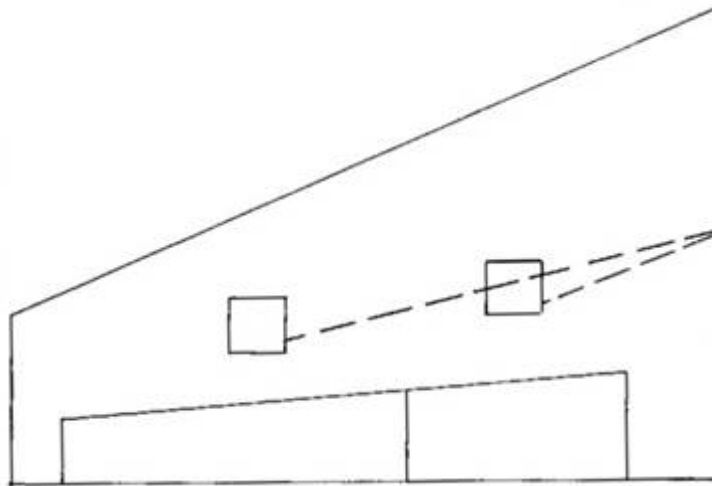

Wooden holders of the servo are enclosed in the building-block system (prepared for Futaba, see the table) which are to be glued in the servo shafts using an epoxide, see the photograph. Upon fitting of the servo using rubber silentblocks (form a part of the servo), use the laminate cover supplied and secure it using screws 2.5x12.



Make a vertical slot in the aileron using a file (into the depth of about 5 mm), to be used for the pin suspensions, see the figure. **This slot must reach into the aileron in such a manner so that the suspension axis is in accord with the aileron rotation axis.**

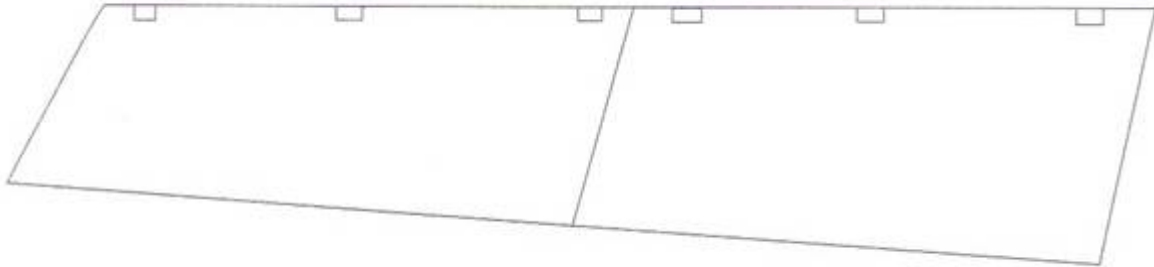

Then drill into the aileron an opening for the suspensions, using the 4.5mm drill. The opening and the aileron entering edge must contain the angle of 90° . Transfer the suspension positions to the wing and again, at the angle of 90° with the following edge of the wing, drill out an opening of the diameter 4.5 mm. Check the rudders function and proper settlement.

Now fit the wings to the model body using the duralumin tube and wooden pins. **The wings MUST have a negative dihedral of about $1.5 - 2^\circ$.** This adjustment is prepared from the production process and its checking is simple. The bottom side of the wings lies in the same plane as the body. If everything is all right, grind the wings and the rudders using the abrasive paper K220 so that there are no irregularities on the surface. During grinding, grind out the following edge of the wing and rudders as thin as possible, in the direction from the bottom side of the wing. This shall not disturb the wing autostable profile!

Tip! During grinding, use the supplied polystyrene casing of the wing and fix the ailerons using a band.

Upon covering the wings with the foil, it is time to perform the final assembly of the ailerons. Redrill the openings in the wing (using a drill, or preferably a milling machine or hot wire) for the diameter of about 9 mm. Glue into the ailerons the pin suspensions (hinges) using the epoxide with microballoons and cotton. Check whether they are really settled at the axis position and at the angle of 90° , all in the same depth. Then fix them and let them harden.

Insert the same glue mix in the drilled wooden dowel of the suspension which forms a part of the building-block system and slide it on the aileron suspension.

Glue this set up unit in the wing, see the figure.

Tip! Before the gluing process, grease the pin suspension joint using vaseline, oil etc.

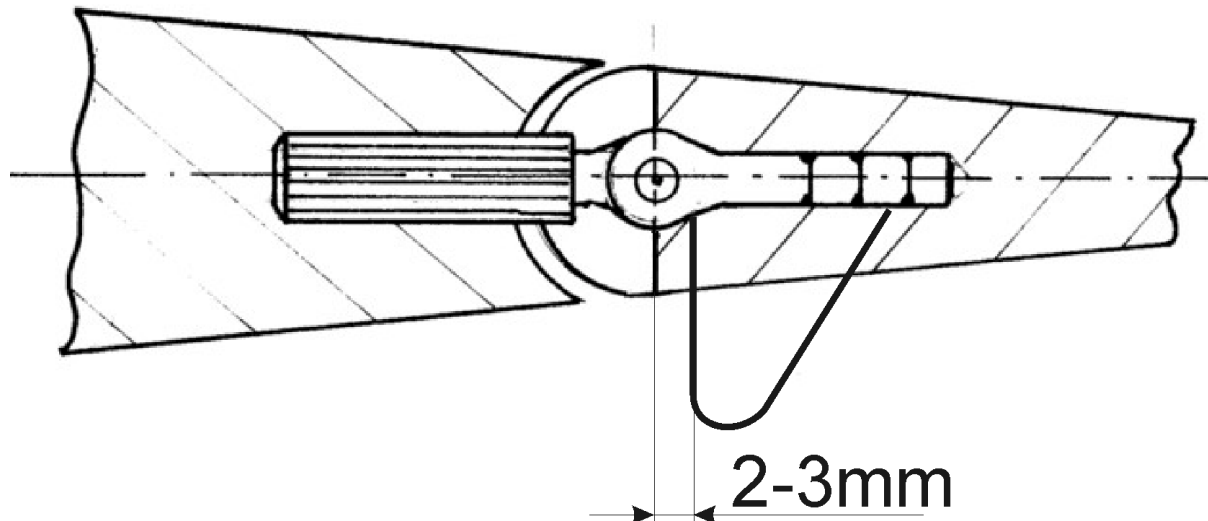

In the end, mark on the aileron the place for gluing of the aileron lever and cut out an opening. It is good to make a small hole in the polystyrene using a thin heated wire and then, using a syringe, insert the epoxide thickened by microballoons or cotton into this hole and fit the laminate lever. Of course, it is to be fitted in such a manner so that the servo pull rod fork is anchored in the aileron lever as close to the rotation axis of the aileron suspension as possible.

VI. Direction Indicators

Upon cursory checking of the direction rudders and loose fitting, coat, using an antiadhesion agent (parquet wax...), the direction indicator profile on the body and part of the direction indicator metal pins which are slid into the body. It is suitable to cover the direction indicator rib on the body using a covering band so that the direction indicator does not accidentally become glued to the body. Then fasten the direction indicator pins using the screws M4 from the building-block system to the body, remove a little of polystyrene from the direction indicators (see gluing of the aileron lever), fill the openings with the epoxide-microballoons mix and fit the direction rudders. Upon hardening, grind everything and coat with the foil.

VII. Model Equipment

The building-block system includes a 2litre PET bottle for the fuel. In the process of making the cable installation in the Hornet, remember that the servo, receiver and aerial conductors must be as distant as possible from the supply cables of the turbine and of the pump. Therefore you should perform the internal electrical installation similarly as in the figure.

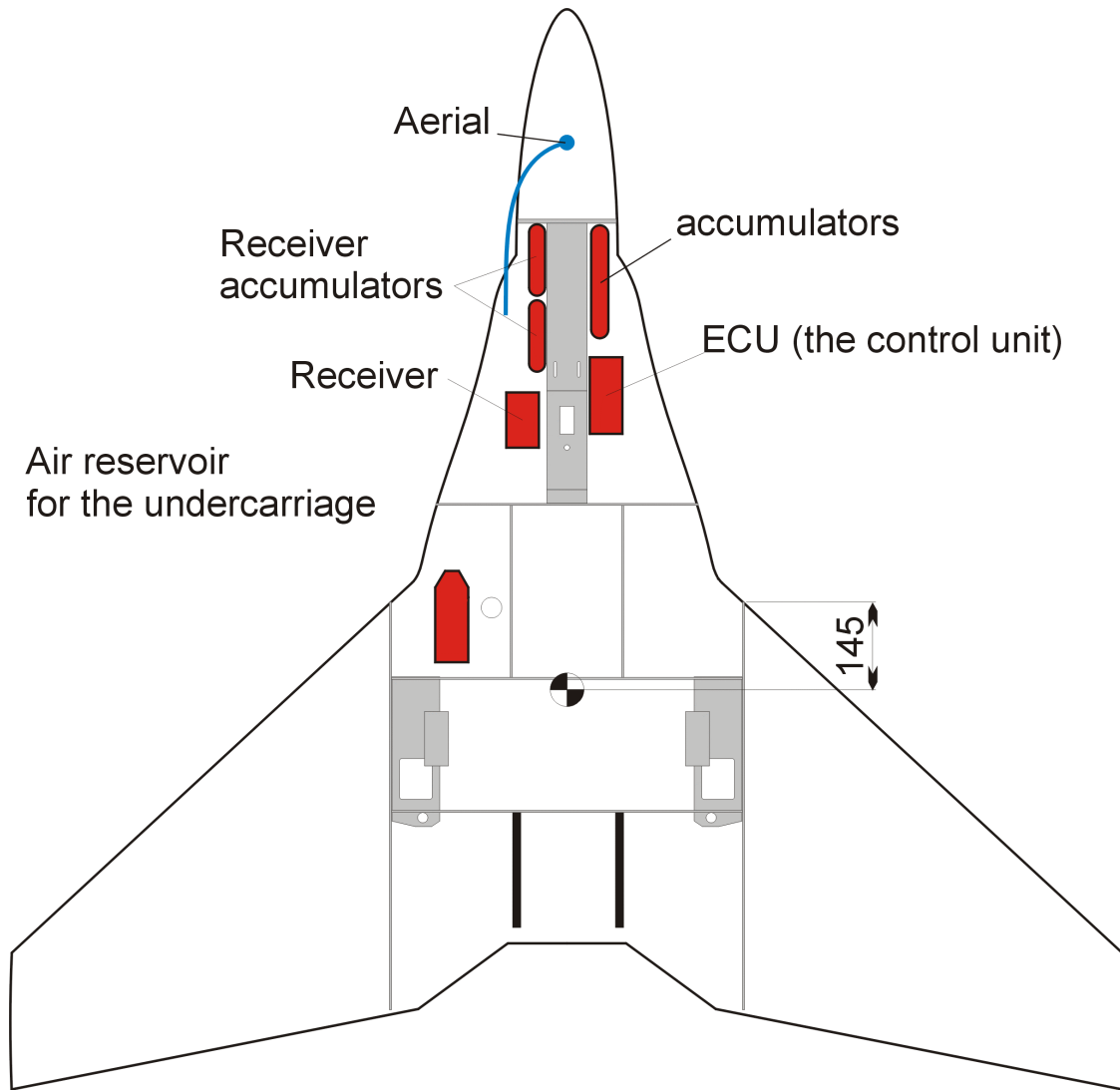

VIII. Model Adjustment

Adjust the undercarriage in such a manner so that the model can stand at the haunch angle of about $+2^\circ$ (the front undercarriage foot is slightly longer than the back one).

The centre of gravity position is 145 mm

from the wing entering edge (measured at the place of the body and wing connection).

Rudder Displacements

| | |
|----------------------|------------|
| Elevator | 28-30 mm |
| Ailerons | 15 mm |
| Speedbrake, degree 1 | 30 degrees |

| | |
|-----------------------|------------|
| Speedbrake, degree 2 | 90 degrees |
| Undercarriage turning | 35 degrees |

IX. Flying

For the first flights, it is convenient to use Expo 25-40% for the ailerons. Upon the pre-flight check and starting of the engine, apply the brake, shift out the braking flap at degree 1, draw fully the elevator and apply full fuel. Upon lifting the brake, your Hornet will break forth agilely and after several metres it will take off. Only then start levelling the elevator slowly, held all the time during the start. Shift in the flap, the undercarriage and the sky is yours!

Wild Hornet is a very good plane, no spin downfall threatens in case of the air flow interruption. The very interruption of the air flow is achieved only when the model is almost stopped.

Flying with WILD HORNET is simply as beautiful as a dream!

The model easily exceeds the speed of 300 km/h, when flying from high altitude down to a low altitude passing, it achieves speeds of 350-400 km/h; it may happen that your eye will be too slow...

Landing

If the engine is running during landing or if there is no wind, shift out the braking shield to degree 2 (if possible, use the "Delay" function).

X. Safety Instructions

- in flying, use only verified RC equipment
- before flying, test the transmitter range
- charge and maintain in good condition all batteries
- fly only above approved flying terrains
- do not fly above people and animals
- be thoughtful about others
- flying low is an unnecessary risk
- program emergency switching off
- Wild Hornet has been tested for the maximum speed of 400 km/h; when a stronger turbine is used, set this value on the speed sensor.

